

(BE) (DE)

Klemm-Dachfenster

(BE) (FR)

Fenêtre de toit à clic

(BE) (NL)

Klemdakraam

(ES)

Ventana de techo de pinza

(CZ)

Svorka střešního okna

(PL)

Zacisk światlika

(SL)

Spona strešnega okna

(HU)

Clamp tetőablak

(IT)

Lucernario a morsetto

(PT)

Braçadeira para claraboia

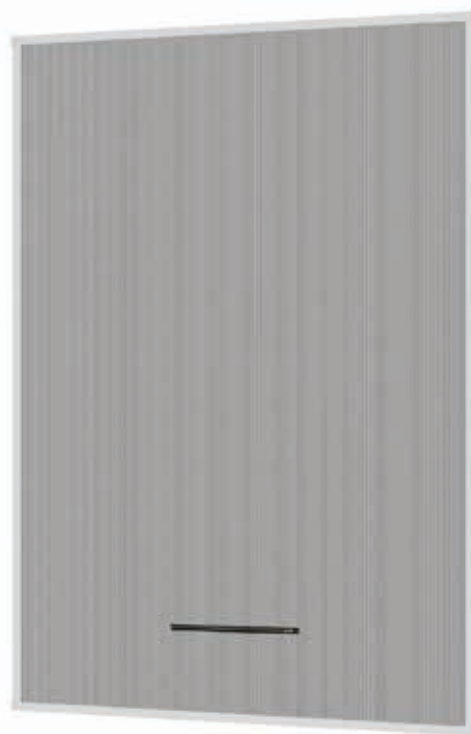

Montageanleitung

Instructions de montage

Montagehandleiding

Instrucciones de montaje

Návod k montáži

Instrukcje montażu

Navodila za sestavljanje

Összeszerelési útmutató

Istruzioni di montaggio

Instruções de montagem

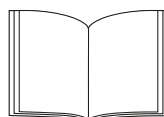

Art. 1021803



**Bitte vor Montage sorgfältig alle Punkte lesen!
Anleitung aufbewahren und bei Weitergabe des Produktes mit aushändigen!**

Bestimmungsgemäßer Gebrauch

Das Insektenschutzprodukt darf nur für den bestimmungsgemäßen nicht gewerblichen Gebrauch (Montage zum Schutz vor Eindringen von Insekten im privaten Bereich) verwendet werden. Bei missbräuchlicher Nutzung kann es zu erheblichen Gefährdungen kommen. Zusätzliche Belastungen dieses Produktes durch angehängte Gegenstände oder Bedienung über die mechanischen Begrenzungen hinaus können zur Beschädigung des Produktes führen und sind daher nicht zulässig. Für hieraus resultierende Schäden haftet der Hersteller nicht.

Sicherheitshinweise

Folienbeutel und Kleinteile von Kindern fernhalten!
ERSTICKUNGSGEFAHR!

Haftung

Bei Nichtbeachtung der in dieser Anleitung angegebenen Hinweise und Informationen, bei nicht bestimmungsgemäßem Gebrauch oder bei Einsatz außerhalb des vorgesehenen Verwendungszweckes, lehnt der Hersteller die Gewährleistung für Schäden am Produkt ab. Die Haftung für Folgeschäden an Elementen aller Art oder Personen ist ausgeschlossen.

Reinigung

Verwenden Sie zur Reinigung nur ein feuchtes Tuch mit mildem Reinigungsmittel. Das Gewebe können Sie mit einem Staubsauger (mit Bürstenaufsatz) oder Handbesen von Staub befreien.

Entsorgung

Denken Sie an den Umweltschutz. Zur Entsorgung von Verpackungsmaterialien und Altgeräten gibt es ein öffentliches Rücknahmesystem. Auskünfte über Sammelstellen und aktuelle Bestimmungen erhalten Sie bei Ihrer Stadt- oder Gemeindeverwaltung.



- Verwenden Sie benötigtes Werkzeug umsichtig um Verletzungen zu vermeiden. Tragen Sie Schutzausrüstung (z. B. Schutzbrille).
- Stellen Sie vor der Verwendung sicher, dass alle Teile unbeschädigt und vorhanden sind. Beginnen Sie keine Montage bei Fehlteilen oder beschädigten Teilen.

Garantie / Gewährleistung

Es gilt die gesetzliche Gewährleistungspflicht.

Von der Garantie / Gewährleistung ausgenommen:

- Unsachgemäße Benutzung
- Unsachgemäße Montage
- Schäden durch zu aggressive Reinigung
- Schäden durch nicht originale Ersatzteile
- Schäden durch Verletzung der Sorgfaltspflicht
- Verschleißteile
- nicht vorgesehene Verwendung

Service

hecht international GmbH | Im Herrmannshof 10 | 91595 Burgoberbach | GERMANY | +49 (0)9805-93331981
www.hecht-international.com/service

Symbolerklärung

Nachfolgend gelistete Warnsymbole werden in dieser Montageanleitung verwendet.

	Klemmgefahr! Bei der Montage oder Justagearbeiten besteht die Gefahr von Klemm-/Quetschverletzungen!
	Schnittgefahr! Bei der Montage besteht die Gefahr von Schnittverletzungen!
	Hinweis / Aufmerksamkeit Bei der Montage ist besondere Aufmerksamkeit gefordert, Ansichten zu beachten oder eine Handlung auszuführen!
	Achtung! Mögliche Sachbeschädigungen oder anderweitige durch Unachtsamkeit entstehende Verletzungen/Gefahren!
	Wichtige Information! Wichtige Information für Montage und Funktion!

Werkzeug

Gereedschap - Outils - Herramienta - Nástroj - Narzędzie - Orodje - Szerszám - Strumento - Ferramenta - Værktøj

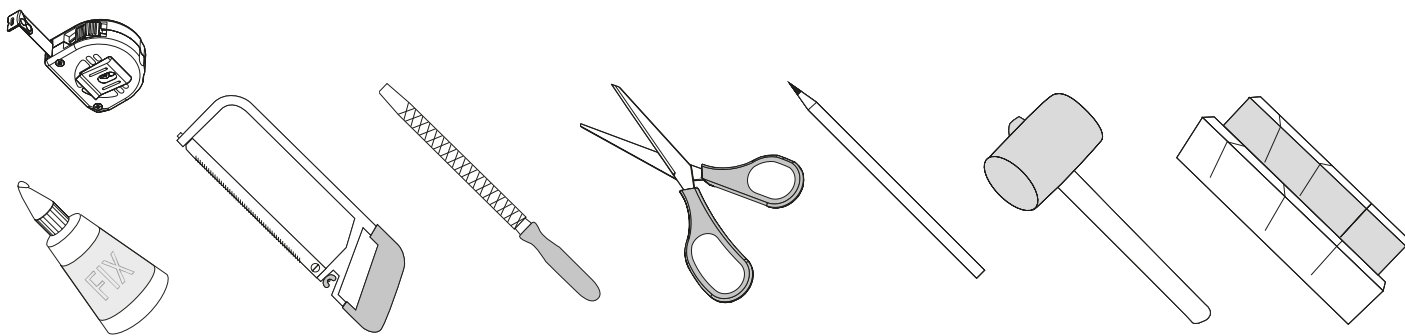

Montagehinweis

Montage-instructies - Instructions de montage - Instrucciones de montaje - Pokyny k montáži - Instrukcje montażu - Navodila za montažo - Szerelési útmutató - Istruzioni per il montaggio - Instruções de montagem - Instruktioner til montering

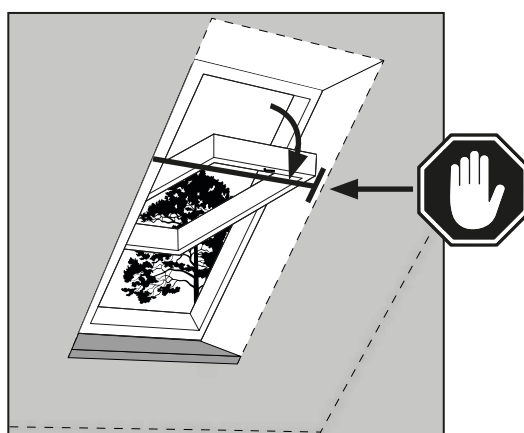
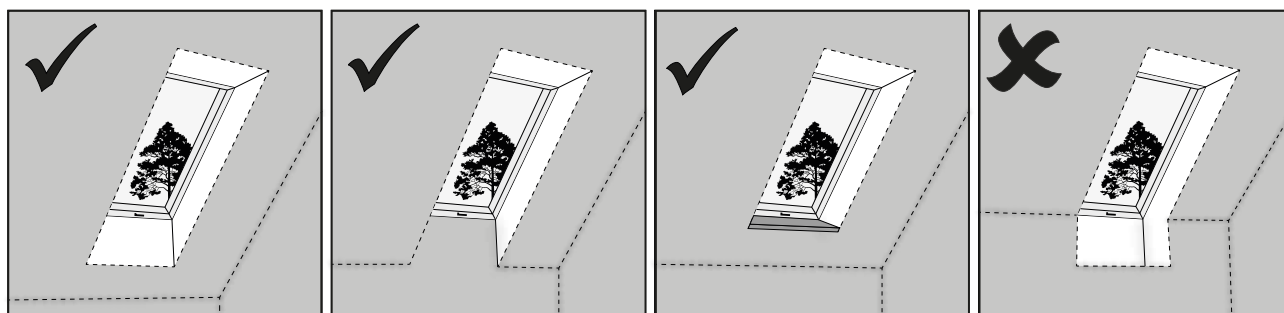

Lieferumfang

Leveringsomvang - Contenu de l'emballage - Volumen de suministro - Rozsah dodávky - Zakres dostawy - Obseg dobave - A szállítás terjedelme - Ambito di consegna - Âmbito da entrega - Leveringsomfang

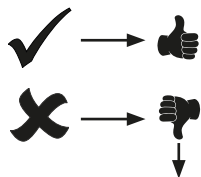
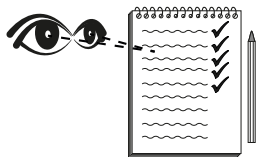

www.hecht-international.com/service

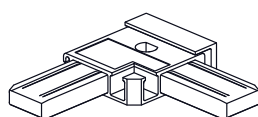
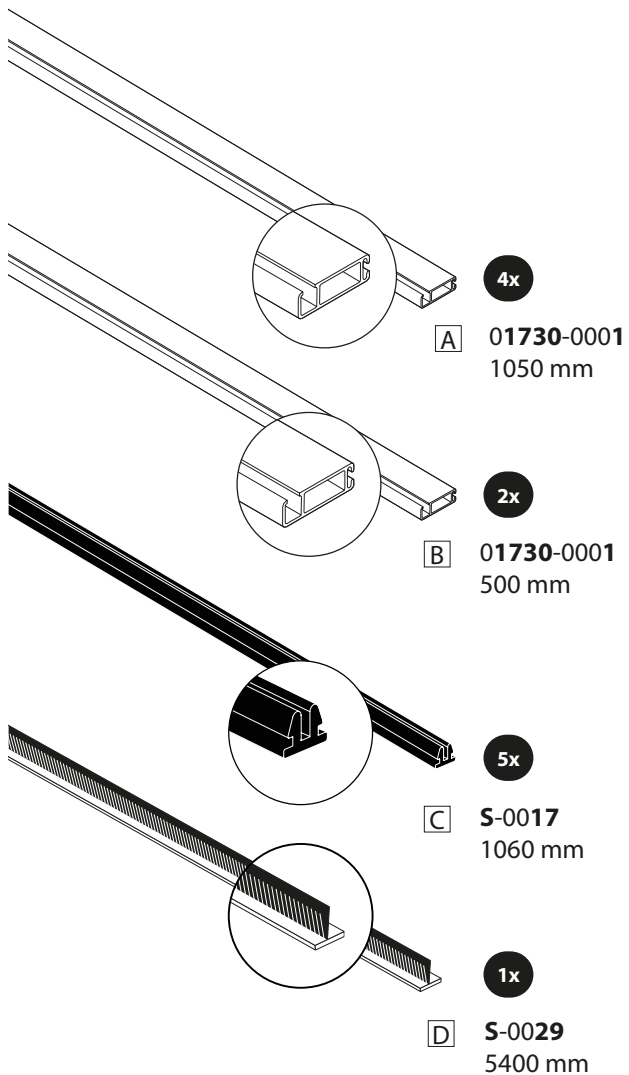

1x

E 01730-1001

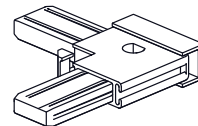
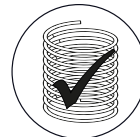

1x

F 01730-1002

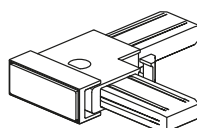

1x

G 01730-1004

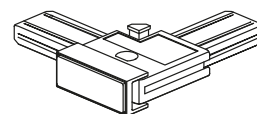
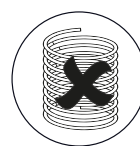

1x

H 01730-1003

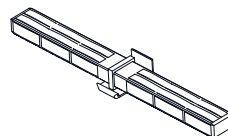

2x

I 01730-0007

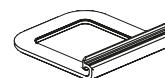

2x

J 01730-0008

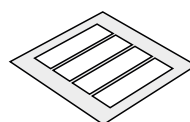

4x

K 01730-0004



1x

L S-0138

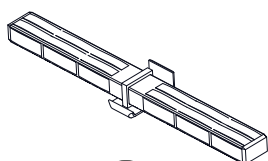
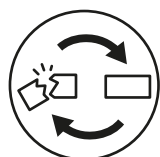

2x

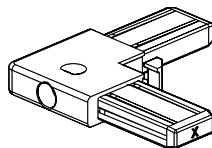

1x

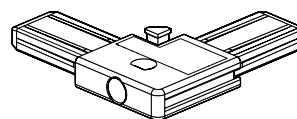

1x

Montage

Montage - Montage - Montaje - Montáž - Montaż - Montaža - Összeszerelés - Montaggio - Montagem - Montering

1

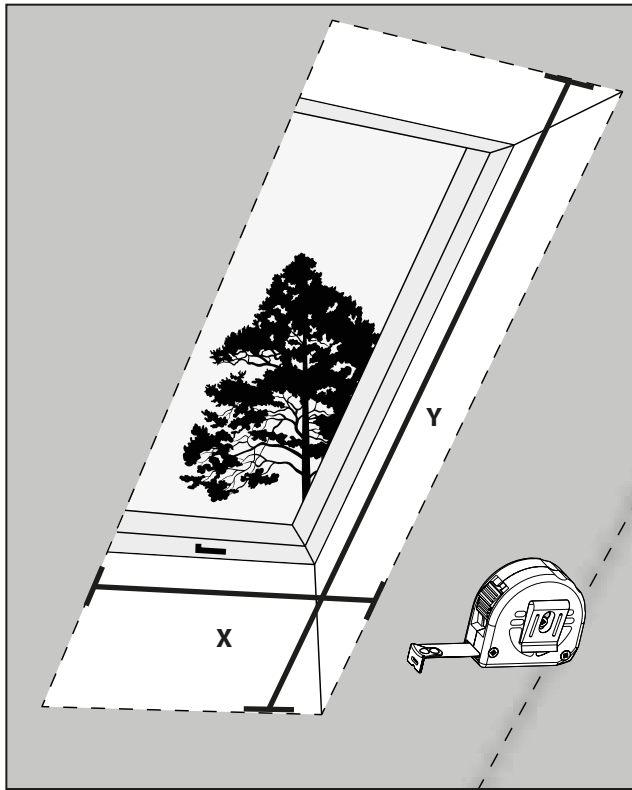

X = _____ cm

Y = _____ cm



Y > 1050 mm

A

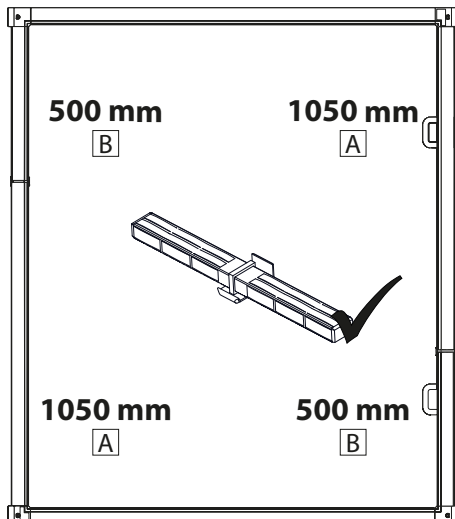

Y < 1050 mm

B

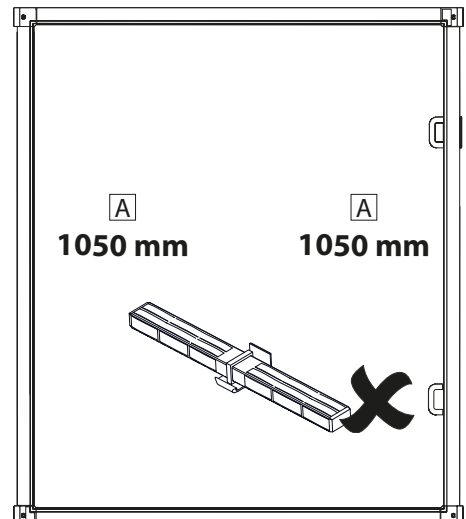

2

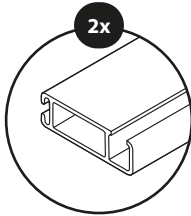
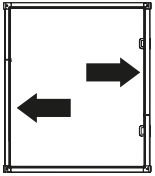

A 01730-0001
1050 mm

A = Y - **B** - 56 mm

B = Y - 53 mm

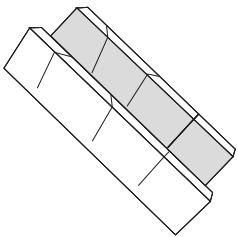
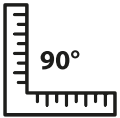

A

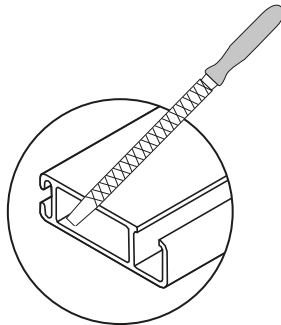
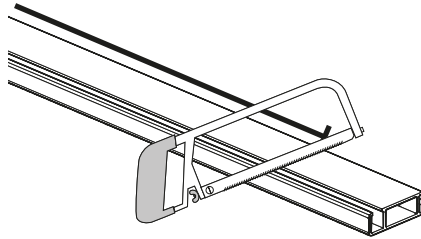

A

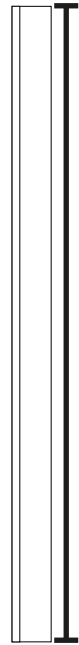

3

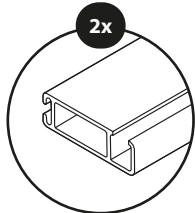
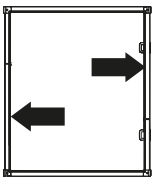

A 01730-0001
1050 mm

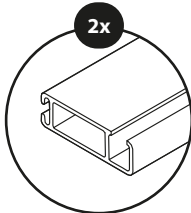

B 01730-0001
500 mm

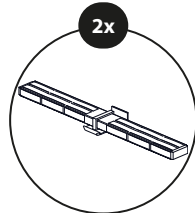

I 01730-0007

A

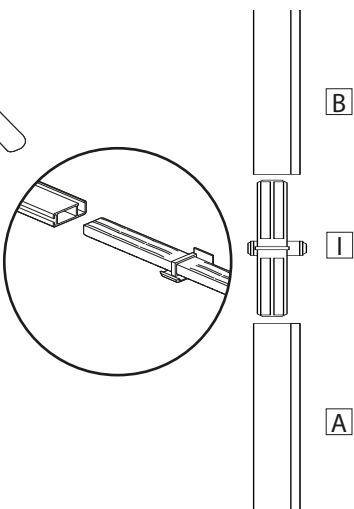
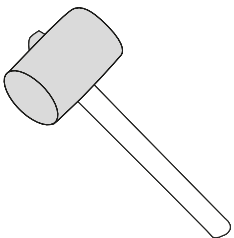

B

I

A

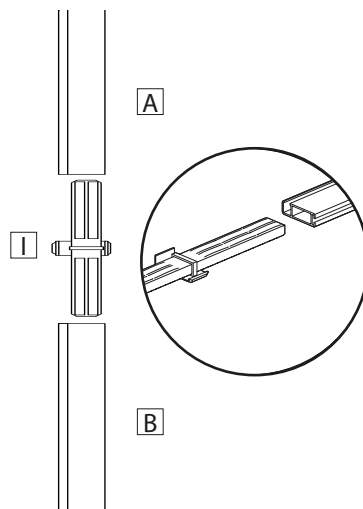

A

I

B

4

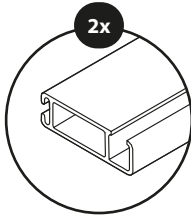
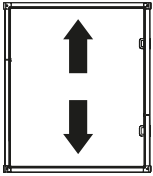

A 01730-0007
1050 mm

A

B

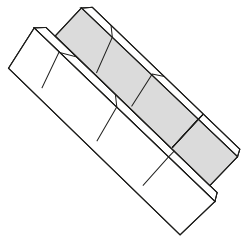
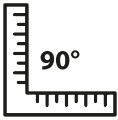

A

= X - 55 mm

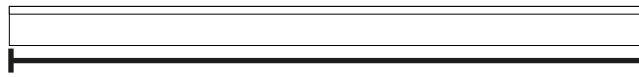
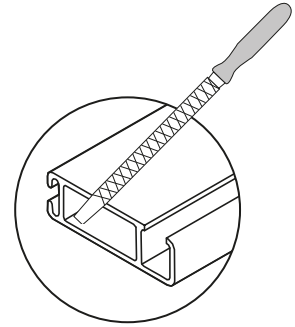
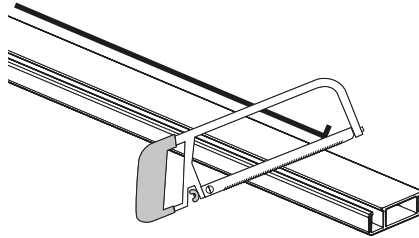
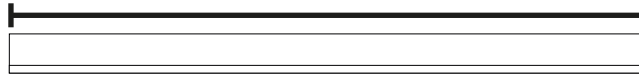

= X - 55 mm

A

5

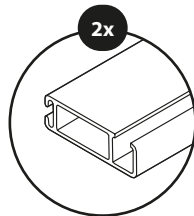
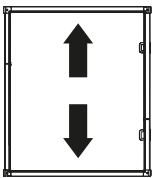

A 01730-0007
1050 mm

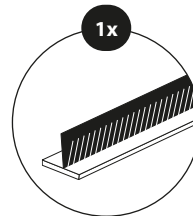

D S-0029

A

B



+ 22 mm

A

+ 22 mm

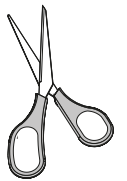
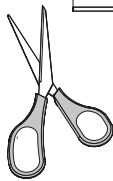
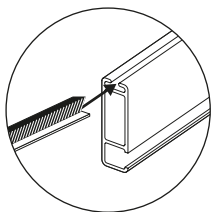

+ 22 mm

A

+ 22 mm

6

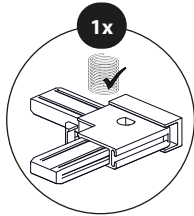
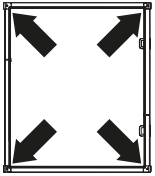

F 01730-1002

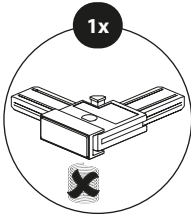

H 01730-1003

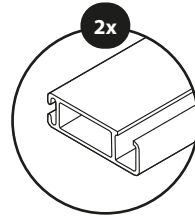

A 01730-001

A

B

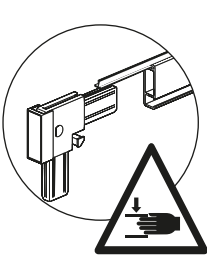
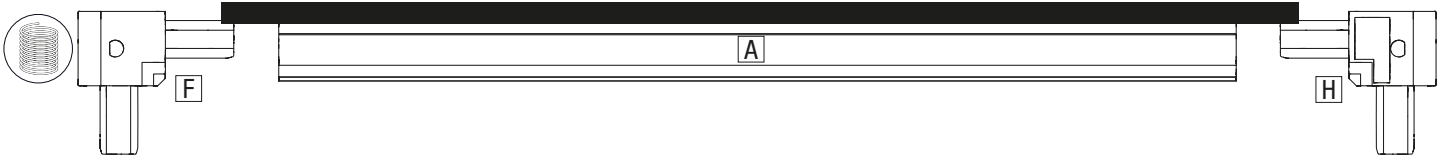

E 01730-1001

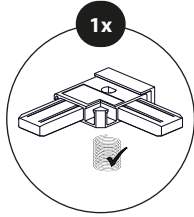

G 01730-1004

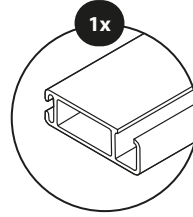
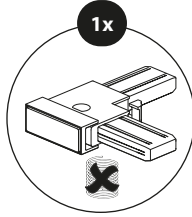

A 01730-0001
1050 mm

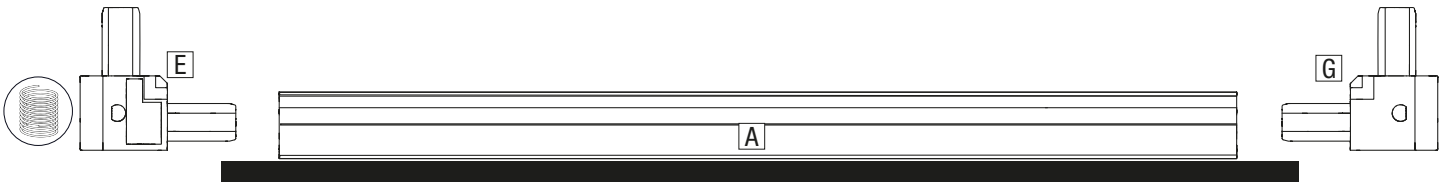
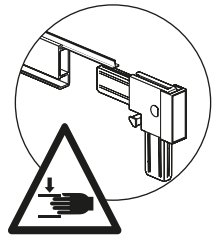

7

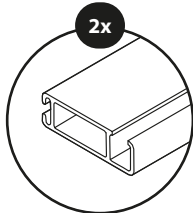

A 01730-0001
(<1050 mm)

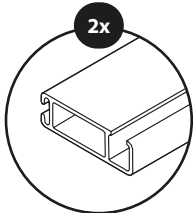

B 01730-0001
(>1050 mm)

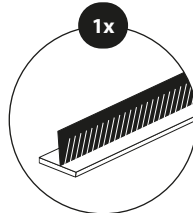

D S-0029

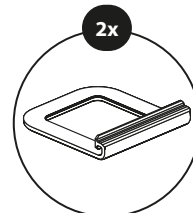

J 01730-0008

A

B

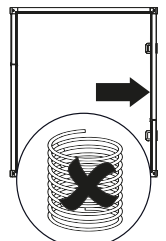
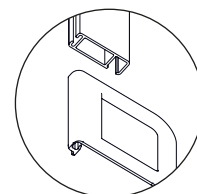
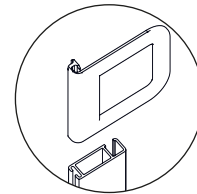
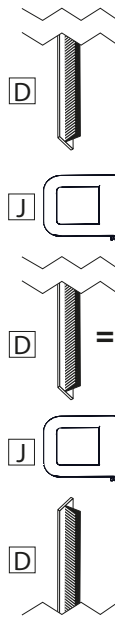
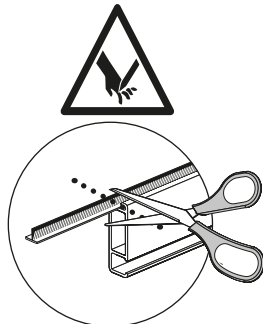
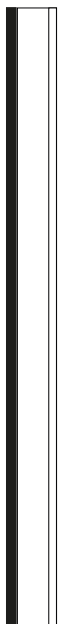
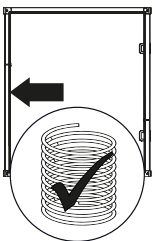

8

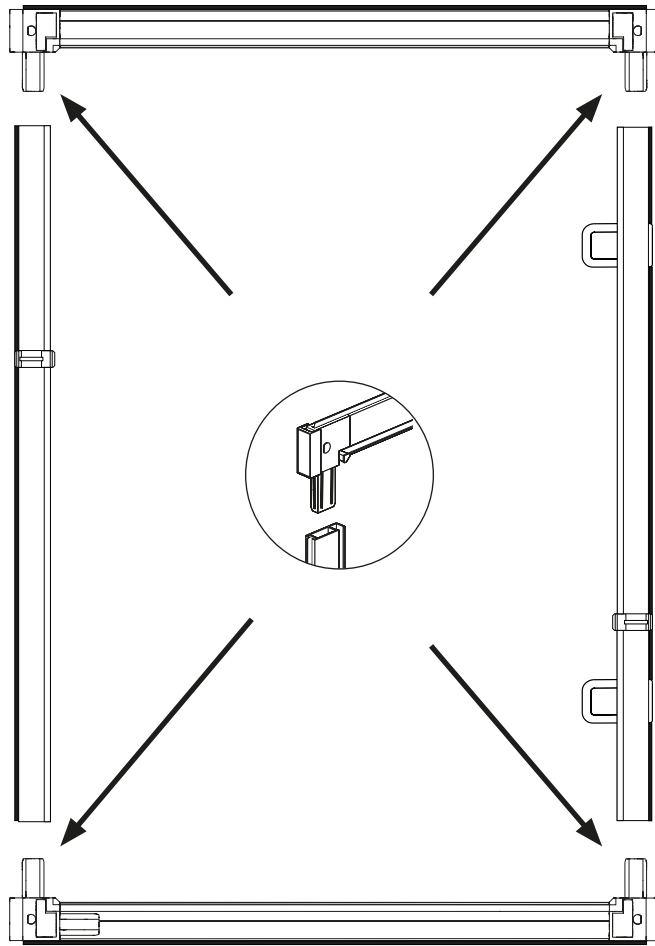

A

B

9

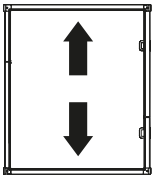

A

B



L S-0138

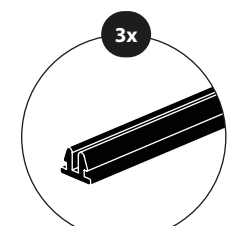

C S-0017

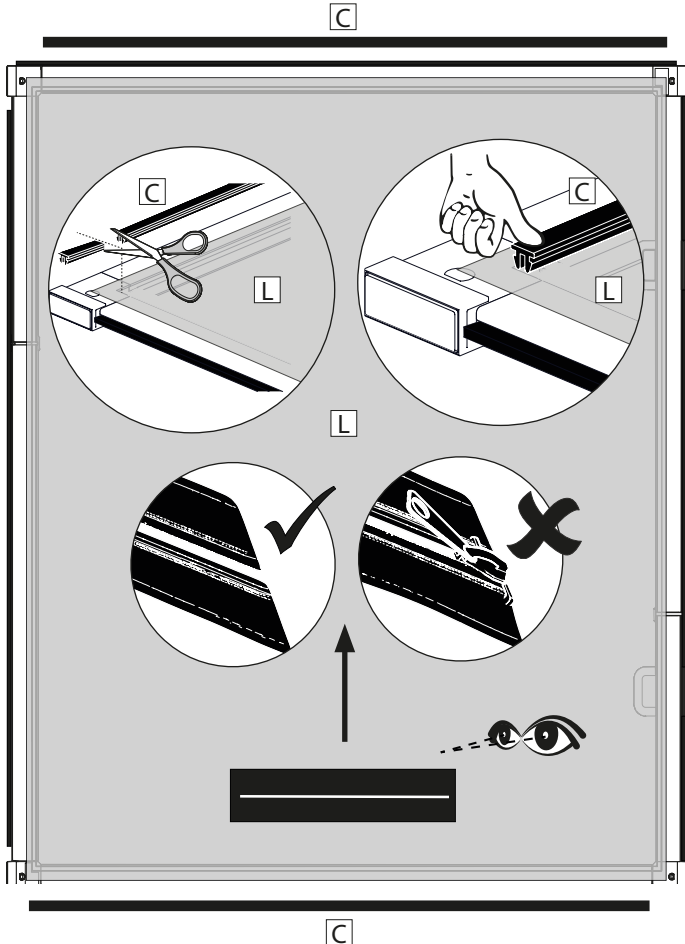

10

A

B

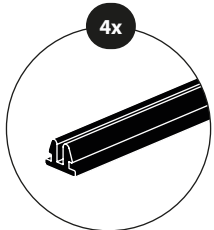
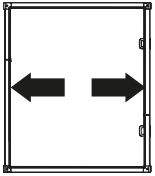

C S-0017

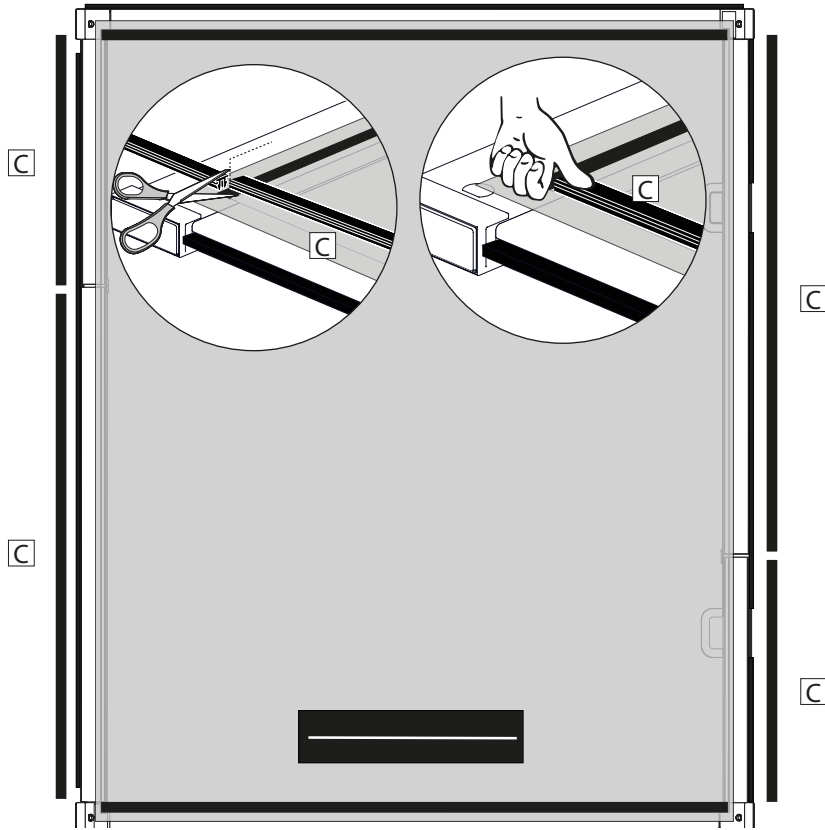

11

A

B

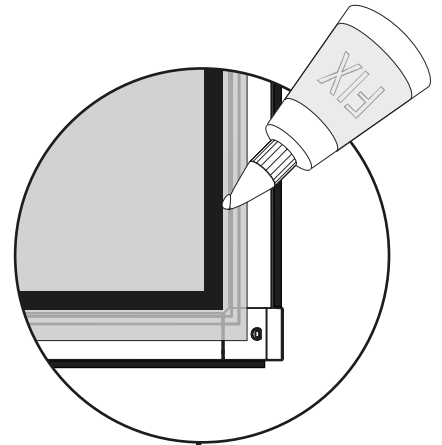
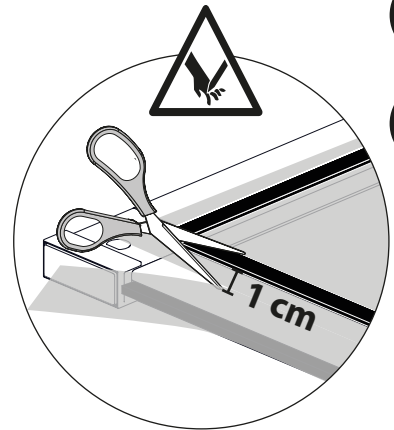
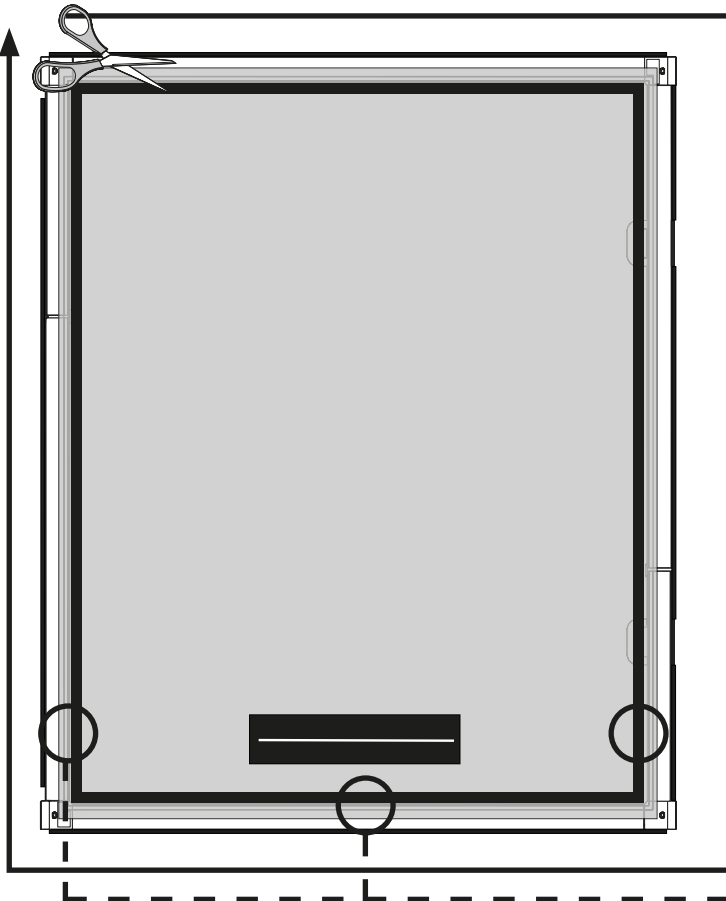
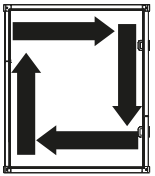

12

A

B

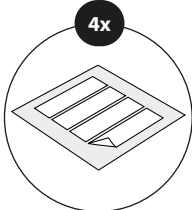
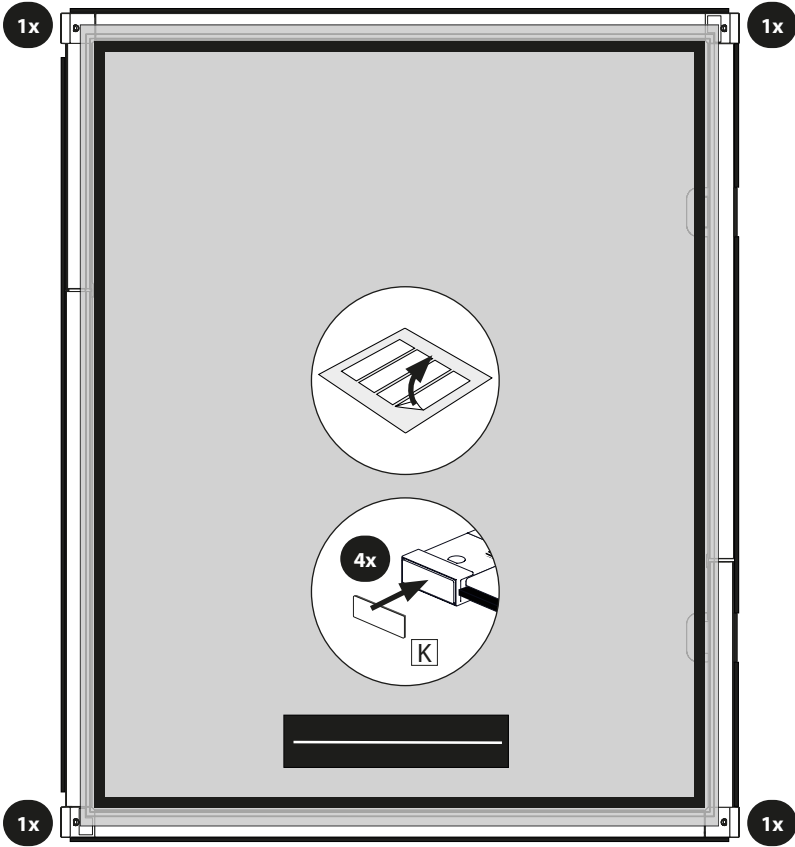
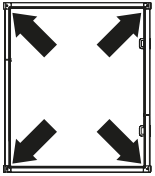

K 01730-0004

13

A

B

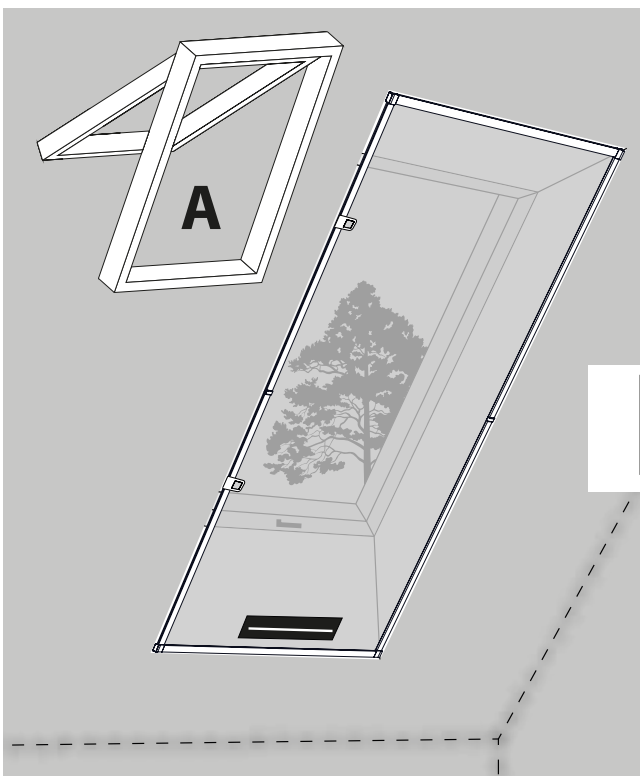

180°

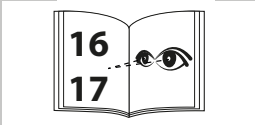
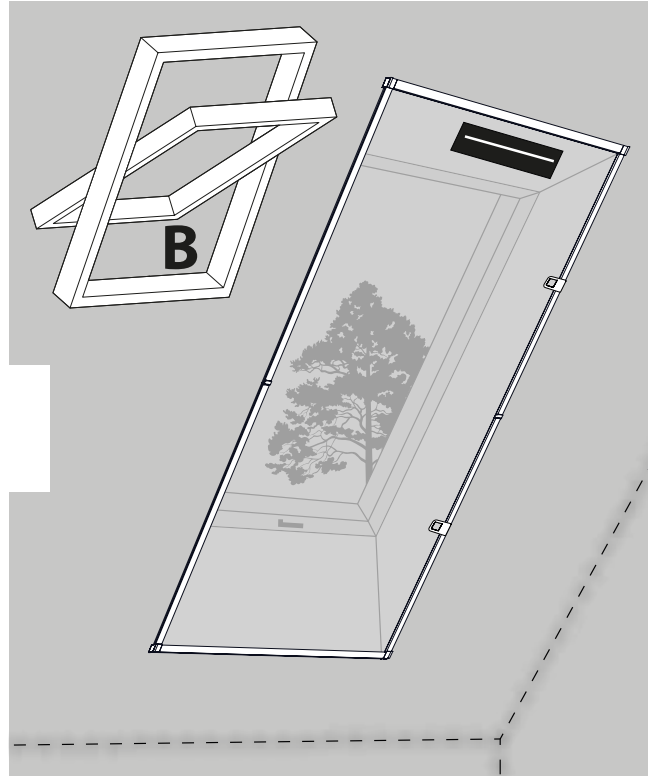

14

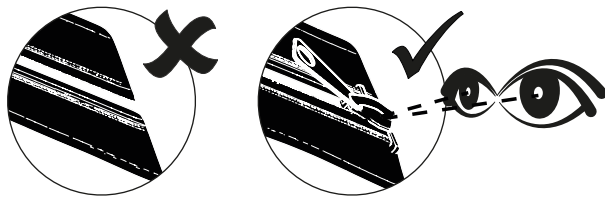

A

B

A

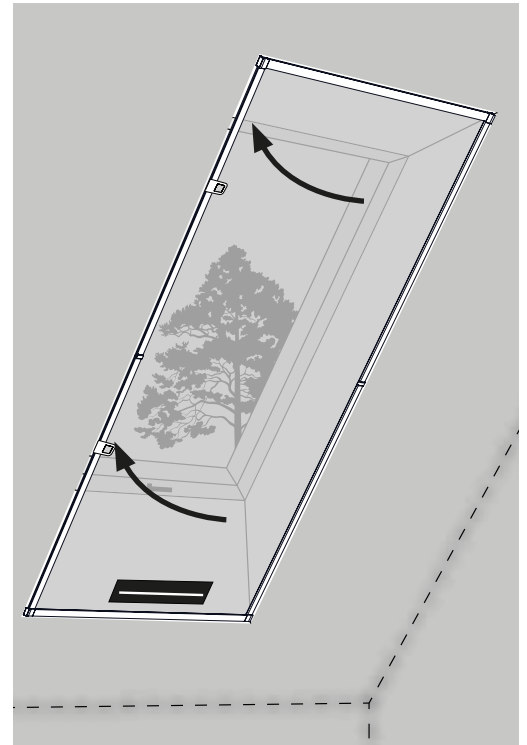
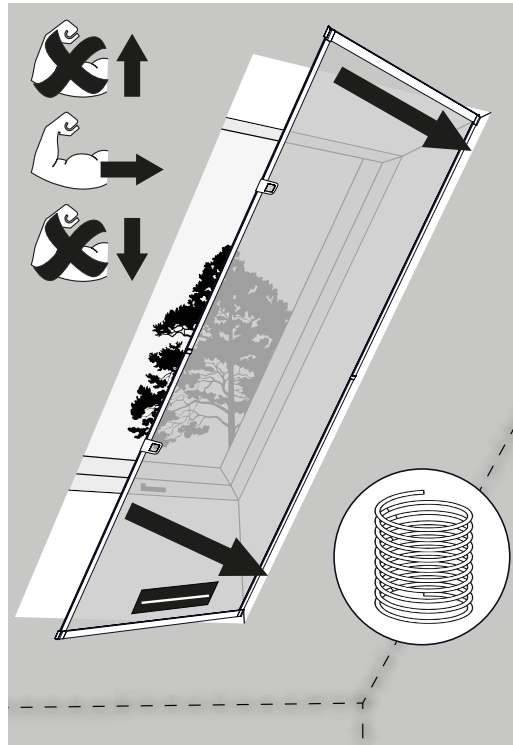
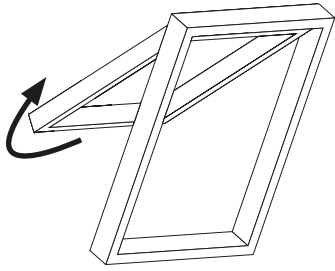

15



A

B

B

